

# MERCURY

AUTOMATIC WEIGHT PRICE, LABELLING AND CONTROL SYSTEM



DE

## Automatisches Wiege- und Etikettiersystem

- bis zu 120 V/min
- mit 3 oder 4 Transportbändern
- Ausführung in Aluminium oder Edelstahl
- kombinierter ergonomischer Arbeitsplatz mit Verpackungsmaschinen

IT

## Sistema di peso prezzatura, etichettatura e controllo automatico

- fino a 120 c/min
- con 3 o 4 nastri di trasportatori
- disponibile sia in alluminio o in acciaio inox
- isole di lavoro ergonomiche combinate con confezionatrici

EN

## Automatic weight price, labelling and control system

- up to 120 p/min
- with 3 or 4 conveyor belts
- available in aluminium or in stainless steel
- ergonomic work stations combined with packaging machines

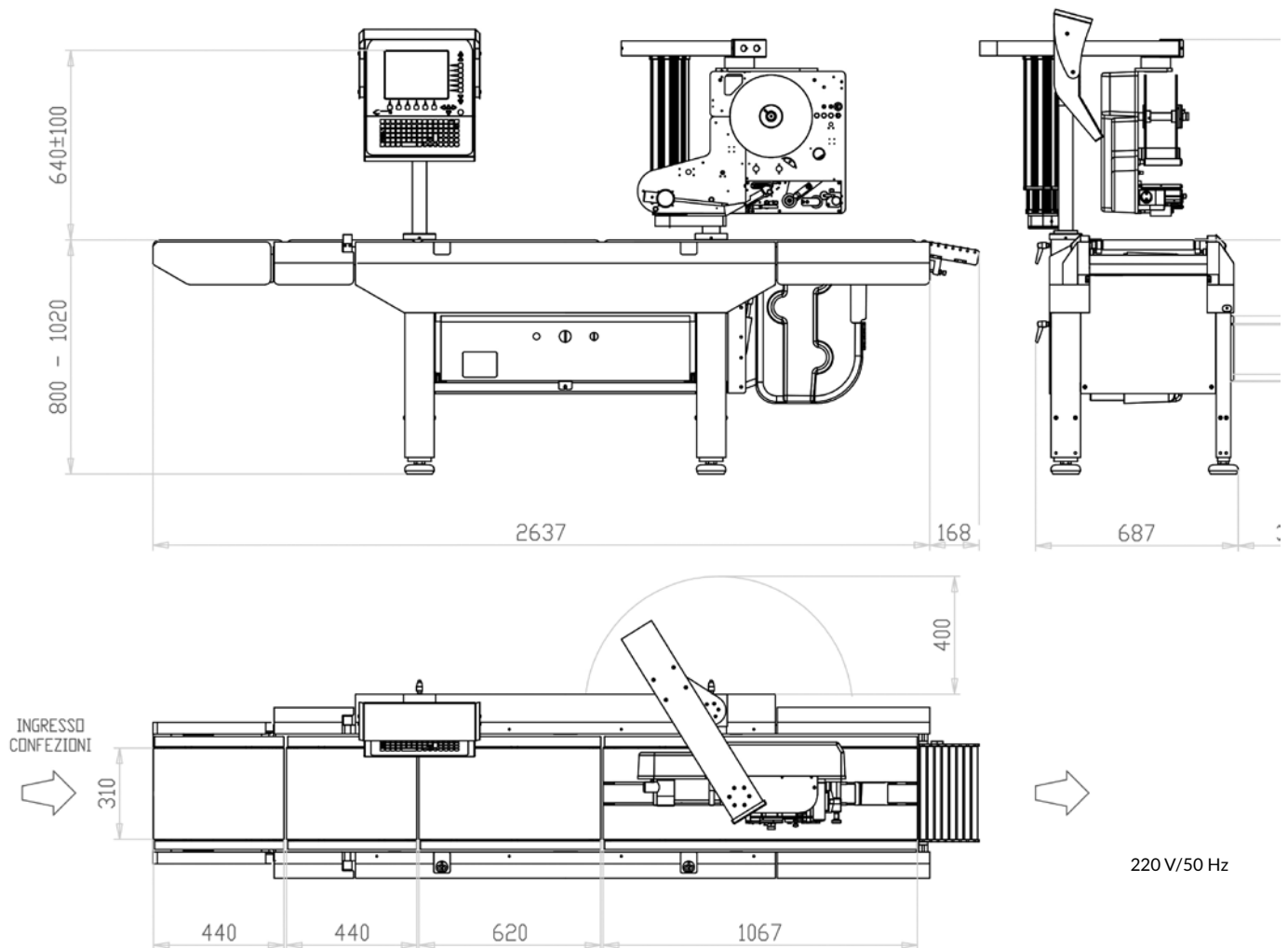

DE

## TECHNISCHE MERKMALE

**400** Packungsgrößen max.  
(L x B x H mm)  
400 x 320 x 250

**6.000** Wiegebereiche von 50g bis  
3000g oder 100g bis 6000g

**102** Druckbreite max. 102 mm  
(Trägerpapier max. 110 mm)

Leicht in **bestehenden  
Linien integrierbar**

Etiketten und Barcodes  
**vom Benutzer programmierbar**

**schneller Etiketten- und  
Thermotransferbandwechsel**

**minimaler Wartungsaufwand  
erforderlich**

IT

## CARATTERISTICHE

**Formato confezione max.**  
(L x l x H mm)  
400 x 320 x 250

**campi di pesatura da 50g a 3000g  
e da 100g a 6000g**

**larghezza di stampa max. 102 mm  
(passaggio carta max. 110 mm)**

Facilmente **integrabile  
in linea**

Etichette e codici a barre **completa-  
mente programmabili dall' utente**

**rapida sostituzione dei supporti  
di stampa e del nastro a trasferi-  
mento termico**

**ridotta necessità di manutenzione**

EN

## SPECIFICS

**max. packages dimensions**  
(L x W x H mm)  
400 x 320 x 250

**weight ranges from 50g to 3000g  
or 100g to 6000g**

**max. printing width 102 mm  
(max. paper width 110 mm)**

Easily **integrated  
in-line**

Labels and barcodes are **fully  
programmable by the user**

**quick replacement of the print  
media and the thermal transfer  
ribbon**

**requires minimal maintenance**